



WRITING TO INFLUENCE the Planning Process

OBJECTIVE

To understand how interest groups communicate with the public and decision-makers, such as the Borough Council. To use the appropriate conventions of one means of communication to express opinions derived from The Planning Process lesson undertaken previously.

KEY QUESTIONS

- > What is an 'interest group'? (members of the public who are affected by a planning decision in some way and would like to get their opinions heard and considered)
- > What can an interest group do if it is unhappy with a planning decision? How can it attract support and get its opinions considered? (amongst other things: letters to newspapers, planners, councillors; radio phone-ins; contributions to local/national newspaper articles. Focus will be upon these three)
- > What are the conventions of each of the three means of communication?

SUGGESTED APPROACH

Introduction

Teacher-led class discussion. Link to last lesson: learning about the planning process for land-use. What decision was made? How many people were happy with that decision? What can members of the public do if they are unhappy with a decision? Form an interest group (group of people with similar reaction to the proposal). Why? (larger number of people is more difficult to ignore and seems/is more representative of the whole community) What can the interest group do to influence planning decisions? (get its opinions considered and encourage more members of the public to join in their 'campaign') How? (letters to newspapers, planners, councillors; contributions to newspaper articles; interviews on local radio phone-ins; petitions and so on). Focus will be on three of these.

5 minutes

DIVISION INTO SIX GROUPS > Establish Task

Each group to use one of three pupil instruction sheets (letter/newspaper article/radio interview) to create a way of influencing the planning decision. Each interest group will be heard. At the end of the process there will be a free vote for all pupils: which interest group persuaded you to join in their campaign?

20 minutes

GROUP WORK

Letters > Issue pupil instruction sheet. Dependent upon number in group, work in pairs to write letter to one of: newspaper, planners, councillors

Newspaper Article > Issue pupil instruction sheet. Dependent upon number in group, work in pairs to write article for one of the local papers;

Radio Phone-in > Issue pupil instruction sheet. The whole group will have to collaborate to create one radio show. A tape recorder and cassette may be provided if practicable. Otherwise, the phone-in could be presented as a script or a performance.

10 minutes

GROUP PRESENTATIONS

Remind pupils of free vote at the end of the presentations. Letters and articles to be read out and displayed. Radio phone-in to be performed.

5 minutes

REMINDER OF OPTIONS AVAILABLE > for the Use of the Piece of Land

Issue voting slips or manual voting. Establish the proposal with the most public support. Next session will be the pupils' turn to be a real interest group - completing a questionnaire from the Borough Council designed to give young people a say in how a town centre is being developed.

NB. This topic would be more effective if it was spread over two lessons to allow for more accomplished presentations and higher quality written work. It would be beneficial to continue to maintain the display board, attaching the contributions from the focus groups.



PUPIL INSTRUCTION SHEET 1

TASK - LETTER WRITING

○—————○●
You are writing to voice your concerns regarding the proposed use of land in your area. You may write to a local newspaper, the planning department of the Borough council or a Borough councillor. It may be most effective to work in pairs.

YOUR LETTER WILL NEED TO INCLUDE

Your address > in the top right hand corner, including a postcode.

The date > written with the month in words, underneath.

The name and address of the person to whom you are sending your letter > on the left hand side of the page.

The greeting > Dear (name),

MAIN BODY OF THE LETTER

Introduction > explain BRIEFLY why you are writing the letter;

Main paragraph(s) > explain your reasons for supporting your proposal and your reasons for rejecting the other proposals. Use formal vocabulary and make sure you explain your arguments clearly;

Conclusion > BRIEFLY state what you would like to be done with your opinions. You are likely to want them to be carefully considered by the council / the planners / the public and your proposal to be adopted by the Borough council. Perhaps you want other people to write to the councillors or the papers.

CLOSURE

Yours sincerely

Your signature

Your name > and / or the name of your interest group

Work together to plan your ideas and reasons for the use of the piece of land. Remember to focus on communicating your ideas clearly in formal but not complex vocabulary.



PUPIL INSTRUCTION SHEET 2

TASK - NEWSPAPER ARTICLES

You are reporters writing articles for local papers based upon the proposed use of a local piece of land. A number of interest groups have contacted you to voice concerns. Write an informative article which considers a number of opinions. Dependent upon your group size, it may be more effective to work in pairs, with each pair writing their own article for a different local paper.

YOUR NEWSPAPER ARTICLE WILL NEED TO INCLUDE

Headline > an eye-catching, bold summary of the story, e.g. LOCAL RESIDENTS IN LAND-USE RUMPUS or COUNCILLOR DEFENDS BURGER CHAIN DEVELOPMENT;

Summary > BRIEF idea of the story: local area of land, several different proposals for how it will be used.

Main body > several paragraphs, including:

All the details of WHERE? WHEN? WHAT? WHO? HOW? WHY? > These questions are used by reporters to make sure that they have enough facts for their stories.

Quotations from at least one interest group explaining their opinion > You may also wish to include a quotation from a local resident;

Quotation from a councillor > What will the council be trying to do?;

Conclusion > who will decide what will happen to the piece of land? When? How can any other interested members of the public influence the decision?

You may wish to include a picture of the piece of land and /or a plan of one or more of the proposals. Depending upon the content of your article, you may wish to use a picture of an interest group protesting on the piece of land.

Work together to plan your ideas. Make up any 'facts' that you do not know. Remember to focus on communicating your ideas clearly in formal but not complex vocabulary.

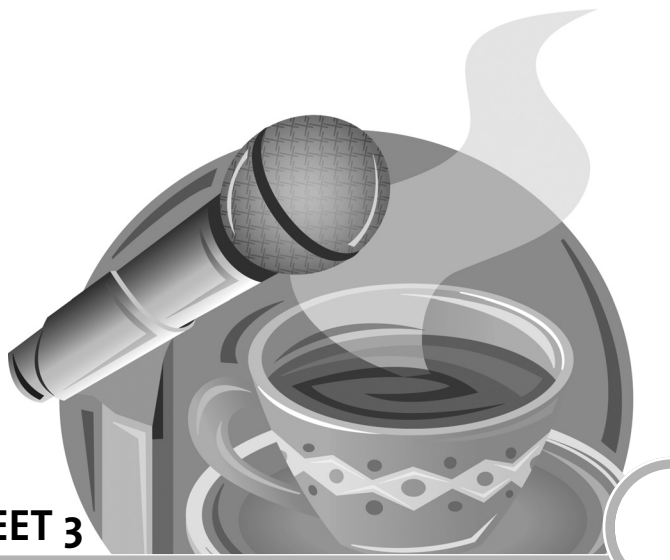

PUPIL INSTRUCTION SHEET 3

TASK - RADIO PHONE-IN

○—————○●
Script and perform a radio phone-in where local residents get the chance to talk to a councillor about the proposals for the use of a piece of local land. Make sure that opinions have clearly explained reasons to support them. You will need to work quickly and effectively as a group to make this happen.

EACH MEMBER SHOULD CHOOSE ONE OF THE FOLLOWING ROLES

Depending upon how many members you have in your group

Local radio presenter / interviewer

Local councillor

Local residents - Choose from parent with young family • elderly person • teenager • middle-aged person, children left home • young adult • planner (optional, a planner would be unlikely to participate in a live broadcast but may issue a statement)

Draft out an outline of a three to five minute radio show where:

- 1] the presenter introduces the topic of local interest > land use in the area;
- 2] the presenter introduces a resident, who provides his/her opinion;
- 3] the councillor responds
- 4] the resident responds to the councillor's statements
- 5] another caller is introduced
- 6] the councillor responds...
- 7] ...and so on until all members of your group have participated. You could end with a comment from the planner, explaining his/her role then a closing comment from the presenter, explaining what interested members of the public should do to make their voices heard.

You will not need an exact script but must know roughly what each person will say. If you can, record your radio show onto a cassette. If this is not possible, be prepared to present it as realistically as possible. Remember that this is a friendly debate NOT an Oprah Winfrey show!